

# Robust Control of Bench-top Helicopter Using Quantitative Feedback Theory

Ameerul Hakeem Mohd. Hairon, Hasmah Mansor\*, Teddy Surya Gunawan, Sheroz Khan

Department of Electrical and Computer Engineering, Kulliyah of Engineering,  
International Islamic University Malaysia (IIUM), 53100 Gombak, Kuala Lumpur, Malaysia

\*Corresponding author, e-mail: hasmahm@iium.edu.my

## Abstract

A three degree of freedom (3-DOF) bench-top helicopter is a simplified aerial vehicle which is used to study the behaviors of the helicopter as well as testing multiple flight control approaches for their efficiency. Designing helicopter's dynamic control is a challenging task due to the presence of high uncertainties and non-linear behavior. In this study, Quantitative Feedback Theory (QFT) is proposed to achieve robust control over the helicopter model. It utilizes frequency domain methodology which ensures plant's stability by considering the feedback of the system and thus removing the effect of disturbances and reducing sensitivity of parameter's variation. The proposed technique is tested against LQR-tuned PID controller to demonstrate its procedures as well as its performance. Simulation results obtained through MATLAB Simulink software shown us that QFT algorithm managed to reduce percentage of overshoot and settling time about 50% and 30% respectively over the classical PID controller.

**Keywords:** quantitative feedback theory, bench-top helicopter, robust controller

**Copyright © 2015 Institute of Advanced Engineering and Science. All rights reserved.**

## 1. Introduction

Countless number of real-life systems nowadays is characterized by extremely high uncertainty which results in great challenge to exert good stability tolerance and performance attribute for closed loop system. To depict the case of a system with high uncertainty, laboratory-scale bench-top helicopter which employs three-degree of freedom (3-DOF) dynamics is used as a reference point and experimental model for verifying the effectiveness of various flight control algorithms.

Achieving high performance control over 3-DOF helicopter is a difficult task due to the essence of a few challenges. Firstly, it is an under actuated system, which means number of control inputs are less than number of outputs to be controlled; in this case it has two control inputs and three outputs [1]. Secondly, there is some close relationship between movement of pitch and travel; the latter is our main interest in this project. Furthermore, multiple variables such as flight altitude, fuel consumption, airspeed and amount of load could affect the plant parameters of the aircrafts and control structure of the system [2]. Due to the facts listed, some general control algorithms will find it hard to perform well at the non-equilibrium points or under model uncertainties. Hence, establishing a robust control algorithm is a challenging task which should not only control the helicopter's three motions (elevation, pitch and travel motion) precisely, but also capable of adapting to surrounding environment and has excellent anti-disturbance properties.

Many works has been done on demonstrating the difficulty to achieve either robust or adaptive control over the helicopter. The method of combination of Linear Quadratic Regulator-Proportional Integral Derivative (LQR-PID) controller was proposed in [3]. However, it is found out that this LQR-PID based controller lacks in terms of accuracy (high steady-state error) and rapidity (settling time) [4]. Another method proposed is multiple-surface sliding controller (MSSC) [5]. Although MSSC was proven to perform better than PID controller, tedious mathematical works are needed to attain the desired equation and gain. Combination of classical PID and fuzzy controller was also proposed in [6] and [7]. It combines the convenient control of PID together with flexible control of fuzzy for 3DoF model helicopter.

In this project, Quantitative Feedback Theory (QFT) controller which was developed by Prof. Isaac M. Horowitz in the early 1970s integrated with the existing LQR-PID controller.

QFT deals with the uncertainty of plant's parameters explicitly to suit the purpose of performance and stability [8]. Through QFT approach, a combination of linearization, quantization and translation of desired performance such as robust stability and robust performance is carried out on set of bounds in Nichols chart; while uncertainties (either structured or unstructured) are converted into areas in Nichols chart called templates. Loop shaping process is then carried out to find the controller parameters by using the Nichols chart that illustrates stability, performance, and disturbance rejection bounds [9]. This can be done by fine-tuning the gains and dynamic elements such as poles, zeros and their complex elements to the frequency response of nominal plant. The processes can be done through interactive environment in MATLAB software which is simple and straightforward to use.

This paper is organized as follows. Section 2 discussed the fundamental knowledge about QFT technique. Section 3 is about the methodology of the research while section 4 presented the results of the simulation as well as the analysis and comparison of the performance of LQR-PID and LQR-PID based QFT (with and without pre-filter installed). Finally, section 5 concluded the research findings.

## **2. QFT Fundamentals**

### **2.1. Plant Template**

In QFT techniques, the plant's dynamics is represented in the form of frequency response which is founded on the principles of frequency loop shaping mixed with the plants' uncertainties [10]. By considering all set of plants instead of a single plant, the magnitude and phase of the plants generate set of points on the Nichols cart at each frequency rather than a single point. Hence a connected region or called template is composed at each selected frequency, which surrounds this set of points.

### **2.2. QFT Bounds**

The major step in QFT approach is retrieving domains in the complex plane (or Nichols chart) by means of converting frequency domain specifications situated on the feedback system. 'Bounds' is used to refer these domains in QFT's list of terms. Final step of the design is accomplished when a nominal loop transfer function is shaped such that it achieves nominal closed-loop stability and lies within its bounds.

### **2.3. Loop Shaping**

Design of the controller is carried out by the process of loop shaping in the Nichols chart. The nominal open-loop transfer function characteristics are plotted together with the composite bound which is evaluated at the trial frequencies. Basically, the designing process involves addition of multiple elements such as gain, integrator, pole and zero and their counterparts [11]. By the operations done, shape of the open-loop transfer function is altered so that the boundaries are compensated at each of the trial frequencies.

### **2.4. Pre-filter**

Loop shaping process guarantees that the closed-loop response of the system fulfills the criterion specified for stability tolerances, also for disturbances in the frequency domain. However, in order to satisfy the tracking specifications, a pre-filter is needed to alter the shape of the system output according to the desired requirements. Introducing the pre-filter in the design will shift the frequency response of the closed-loop transfer functions, which contains plant's uncertainties, into the specification 'envelope' or bound. This will ensure that the desired tracking performance of the final system can be achieved.

## **3. Research Method**

The three degree-of-freedom (3-DOF) helicopter setup for the experiment is manufactured by Quanser Consulting Incorporated. The free body diagram (FBD) of the system is shown in Figure 1 below.

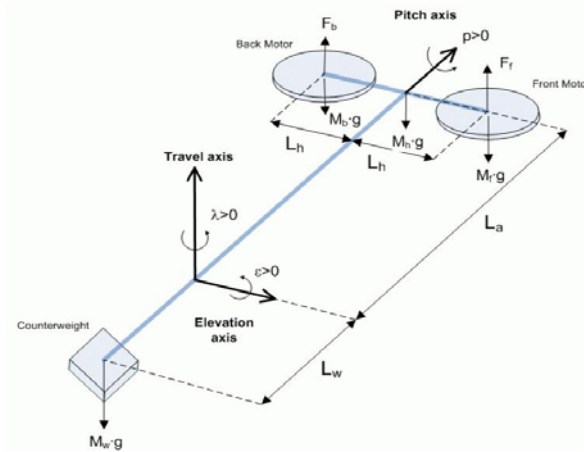

Figure 1. Free body diagram of 3-DOF Helicopter System [12]

**3.1. Modelling of 3-DOF Bench-top Helicopter**

In this project, our main interest is the control of travel angle of the helicopter. Changing the travel direction is quite a challenging task here. This is because travel angle has direct relation with pitch axis; that is the only way to control travel angle is by pitching the body of the helicopter. Figure 2 shows the FBD for travel angle mechanism.

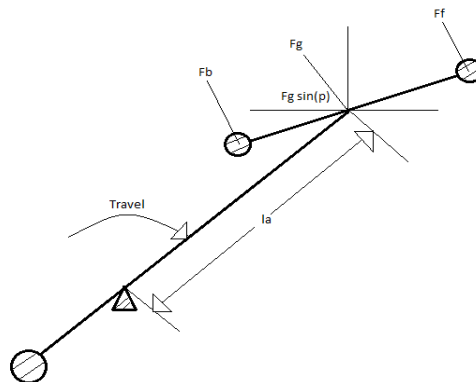

Figure 2. Free body diagram (FBD) for helicopter's travel angle

Referring to figure above, the helicopter's body is assumed to be pitched up by an angle  $\rho$ . For small angles, the force required to keep the helicopter in the air is approximately  $F_g$ . Acceleration with respect to travel axis is the result due to torque produced by the horizontal component of  $F_g$ . The equation associated with travel angle is given in Equation (1) below.

$$J_t r = -K_p \cdot \sin(\rho) \cdot l_a \tag{1}$$

Where  $r$  is travel rate in radian per second,  $K_p$  is the force required to keep the helicopter overhead which is approximately  $F_g$  and  $\sin(\rho)$  is the trigonometric sin of the pitch angle. In addition, no force is sent along the travel axis for zero pitch angle case.

**3.2. QFT Controller Design**

This sub-section will review the implementation of QFT design technique and its basic designing procedure. It presents a detailed discussion of the method and steps with the aim to establish a solid understanding of the fundamental concept of this approach. A QFT design technique commonly comprises these three basic steps:

- Calculation of QFT bounds (robust stability, robust tracking, etc.)
- Designing the controller (or loop shaping)
- Evaluating the design (or possible pre-filter design)

For the systems with parametric uncertainty models, plant templates should be generated before commencing on the first step as in Figure 3. A template is the frequency response of the plant at some fixed frequency. By utilizing the given plant templates, specifications for a closed-loop system is converted into magnitude and phase constraints on a nominal open loop function through QFT process. Term 'QFT bounds' is used to represent the constraints mentioned above.

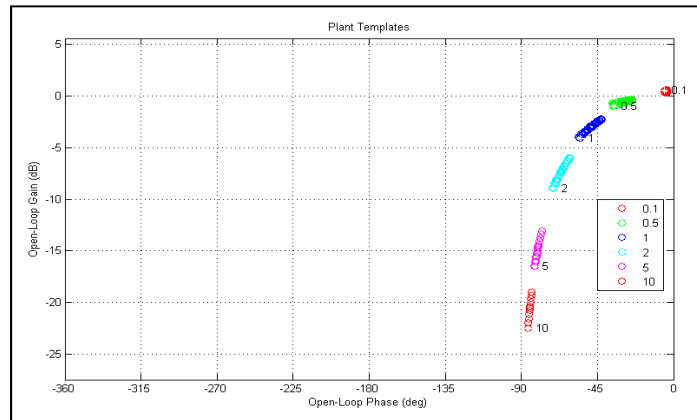

Figure 3. Plant templates with different frequency response

After the formation of the plant's templates, both plant's templates and specifications are used to develop bounds at the trial frequencies in the frequency-domain. There are two conditions for robust stability, or known as Robust Stability Criterion 2 which are:

- Nominal system stability that corresponds to the nominal plant, and
- The Nichols envelope does not converge with critical point  $q$  which is the  $(-180^\circ, 0 \text{ dB})$  point in a Nichols chart or the  $(-1, 0)$  point in the complex plane.

After stability bound shown in Figure 4, the tracking bounds are being put into consideration next. The tracking bounds (as in Figure 5) descriptions should follow the requirement of the output plant which fulfills the desired plant output. Intersection of bounds is determined and the worst case of all bounds is shown in Figure 6. The composite or intersection bound for each value of frequency  $\omega_i$  is composed of those portions of each respective bound (tracking and disturbance if any) that are most restrictive. When there are intersections between two bounds, the outermost of the two boundaries becomes the perimeter. If there are no intersections, then the bound with the largest value or with the outermost boundary dominates. This is the final bound taken for the design of the feedback compensator.

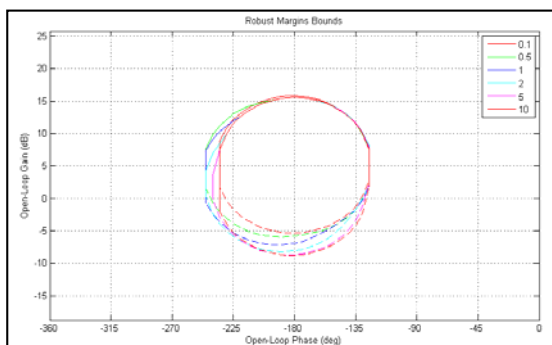

Figure 4. Robust margin or stability bounds

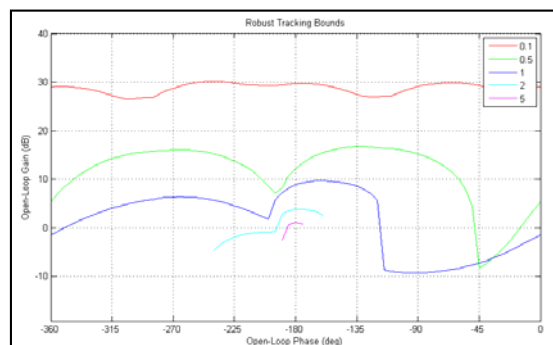

Figure 5. Robust tracking bounds

Having computed the stability and performance bounds, the next step in a QFT design is loop shaping process where the process involves designing a nominal loop function that fulfills its bounds. The nominal loop is the results from combining nominal plant and to be designed controller which has to compensate the worst case of all bounds. In general, the process of loop shaping are composed of addition of poles and zeros as well as gains so that the nominal loop is repositioned near its bounds to ensure stability of the nominal closed-loop function. The loop shaping using InteractiveDesign Environment (IDE) is shown in Figure 7.

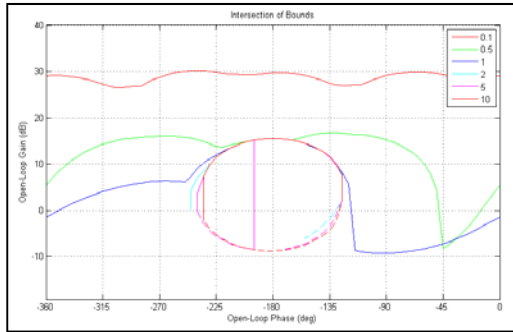

Figure 6. Intersection of robust margin(stability) and tracking bounds

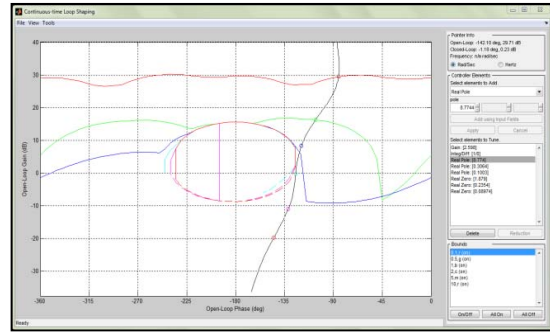

Figure 7. Loop shaping process

The final step in QFT approach is designing the pre-filter to guarantee that output of the system satisfies the tracking specifications. Adding pre-filter into the system will shift the frequency response of the close loop transfer function that contains plant uncertainties into the specification envelope or bounds. The final form of controller  $G(s)$  and pre-filter  $F(s)$  obtained are shown in the Equation (2) and (3) below:

$$G(s) = \frac{2.598 (s-1.879)(s-0.2354)(s-0.0897)}{s(s-8.774)(s-0.3064)(s-0.1003)} \tag{2}$$

$$F(s) = \frac{1.001(s-0.833)}{s-0.696} \tag{3}$$

**4. Results and Analysis**

After finished with the controller design process, the parameters of the controller obtained from the previous process were exported into MATLAB Simulink simulation software for simulation process. In this process, three different setups were tested; the first one being LQR-tuned PID controller next is QFT controller based on PID and the last one is PID-based QFT controller with pre-filter. Figure 8 represents the overall block diagram for testing conducted on the controllers of bench-top helicopter’s travel angle.

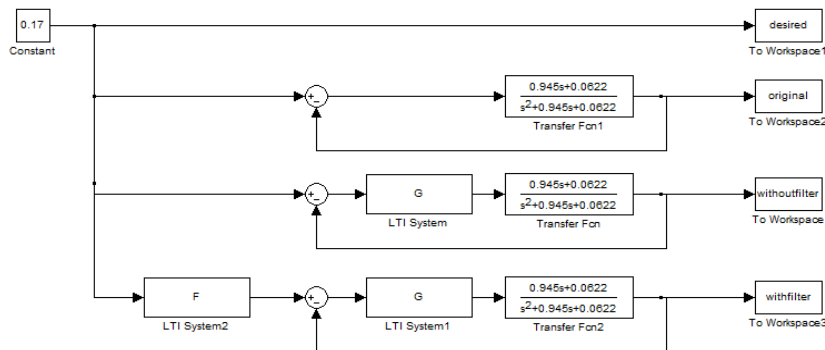

Figure 8. Overall Simulink block diagram for bench-top helicopter travel angle

In this simulation, the outputs of the systems are exported to MATLAB Workspace so that graph plotting can be done easier and in more presentable manner. The block 'Constant' is the set point for the system, in which three different set points had been selected. The reason of selecting these three different cases is to demonstrate the different travel angles desired for the helicopter.

**4.1. Simulation Results**

As mentioned earlier, three different set points had been chosen that is  $10^\circ$ ,  $20^\circ$  and  $30^\circ$  in which their value in radian is 0.52 rad, 0.35 rad and 0.17 rad respectively. Four important performance specifications which are percentage of overshoot, settling time, percentage of steady-state error and control efforts are considered here. The results from simulations conducted are tabulated in Table 1 until Table 3, where the graphs obtained for each case are shown in Figure 9 until Figure 11.

Table 1. Results for set point of 0.52 rad

Specifications	LQR-tuned PID	PID-based QFT	QFT with Pre-filter
Overshoot	2.90%	11.89%	1.87%
Settling Time (s)	32.17	17.22	20.98
Steady-state error	50.53%	5.10%	0.65%
Control effort range	-	0.445-1.094	0.450-0.946

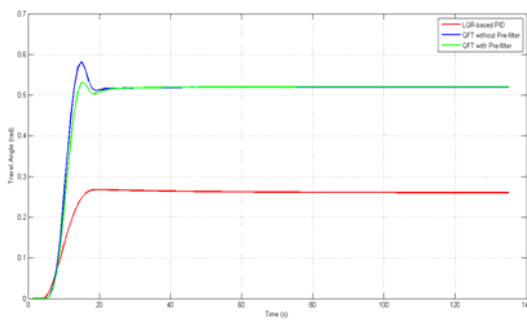

Figure 9. Response of the controllers for 0.52 rad set point

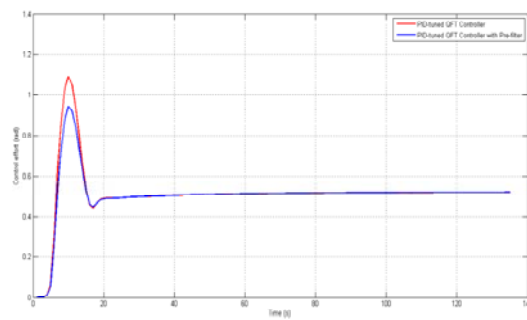

Figure 10. Control efforts of the controllers for 0.52 rad set point

Table 2. Results for set point of 0.35 rad

Specifications	LQR-tuned PID	PID-based QFT	QFT with Pre-filter
Overshoot	2.89%	11.19%	2.18%
Settling Time (s)	31.52	16.75	20.37
Steady-state error	51.29%	1.94%	2.43%
Control effort range	-	0.300-0.730	0.304-0.636

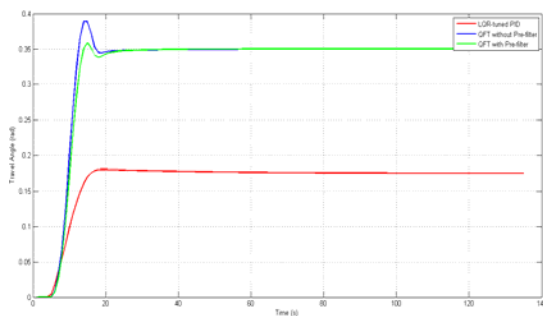

Figure 11. Response of the controllers for 0.35 rad set point

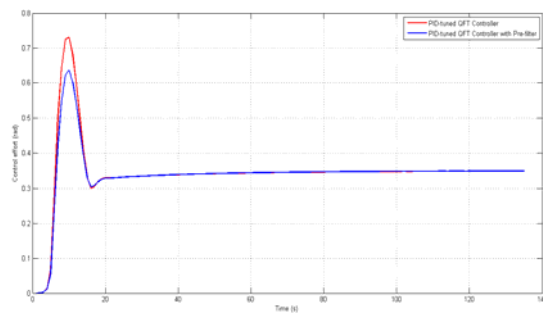

Figure 12. Control efforts of the controllers for 0.35 rad set point

Table 3. Results for set point of 0.17 rad

Specifications	LQR-tuned PID	PID-based QFT	QFT with Pre-filter
Overshoot	2.90%	11.88%	1.71%
Settling Time (s)	31.27	16.39	20.10
Steady-state error	50.71%	5.12%	0.82%
Control effort range	-	0.145-0.357	0.147-0.308

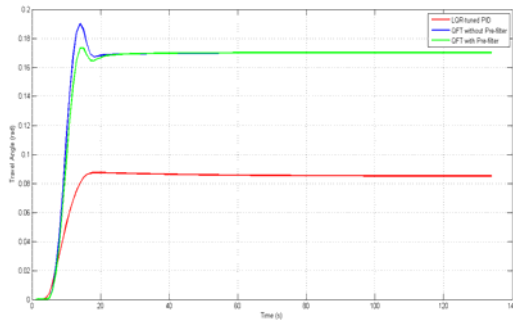

Figure 13. Response of the controllers for 0.17 rad set point

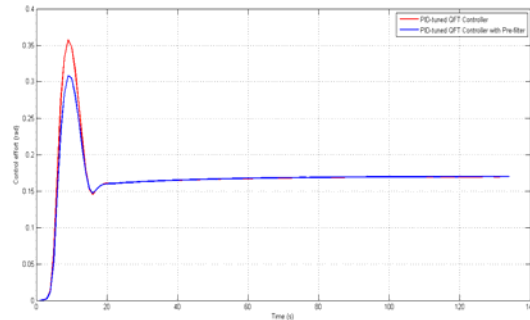

Figure 14. Control efforts of the controllers for 0.17 rad set point

#### 4.2. Results Analysis

The LQR-tuned PID controller which serves as a benchmark for this project exhibits a uniform characteristics throughout the three cases. Even though its percentage overshoot is better than PID-based QFT controller, its steady-state error readings are quite high at about 50% range. In addition, settling time is also the longest among all at around 30 seconds range.

For PID-based QFT controller, simulation shown that it performs best at medium range of travel angle, in this case 0.35 rad or 20°. Compared with LQR-tuned PID controller and QFT controller with pre-filter, it has fastest settling time with lowest percentage of steady-state error which is 16.75 seconds and 0.68% respectively. On the other hand, its percentage of overshoot is the highest in all three cases (11.19% as opposed to 2.89% and 2.18%) as a trade-off with that fastest settling time. This is also undesirable since high amount of overshoot can cause 'clipping' of the control signal.

Addition of pre-filter to the PID-based QFT controller managed to reduce the overshoot percentage dramatically (down to 1.71% from 11.88% in the case of 0.17 rad), performing the best among all controllers tested. Reducing the overshoot came with the cost of delay in settling time, but the delay is still within acceptable range.

Another important aspect that was being put into test is range of control effort. Control effort is defined as the amount of control signal generated by controller as the result of error signal from sensor. For all three cases of travel angle, the pre-filter worked well by reducing the control effort range to about 22-25% lesser compared with QFT controller with no pre-filter installed. Hence, less amount of control signal needs to be generated to achieve the desired results.

#### 5. Conclusion

From the simulation done via MATLAB Simulink software, it can be concluded that the controller design fulfills the desired robust stability and robust tracking performance. This translates to robust control over the uncertainty and disturbances which present in real life situation, in this case helicopter flight dynamics where it is governed by many uncertainties such as air speed, humidity and amount of load carried. To prove the simulation results, these three types of controllers shall be implemented on the actual model of the bench-top helicopter in which fine-tuning of the design may be required later on.

**References**

- [1] Liu Z, Choukri Z, Shi H. *Control Strategy Design Based on Fuzzy Logic and LQR for 3-DOF Helicopter Model*. International Conference on Intelligent Control and Information Processing. Dalian. 2010.
- [2] Mansor H, Zaeri AH, Mohd Noor SB, Raja Ahmad RK, Taip FS, Ali HI. Design Of Qft Controller For A Bench-Top Helicopter System Model. *International Journal of Simulation System, Science & Technology*. 2010; 11(5): 8-16.
- [3] He J, Wang Q, Lee T. *PI/PID Controller Tuning via LQR approach*. Proceedings of the 37th IEEE Conference on Decision & Control. Tampa. 1998: 1177-1182.
- [4] Gao J, Xu X, He C. A Study on the Control Methods Based on 3-DOF Helicopter Model. *Journal of Computer*. 2012; 7(10): 2526-2526.
- [5] Mostafa A, Rini A, Ari L. *Multiple-surface Sliding Mode Control for 3DOF Helicopter*. 4th International Conference on Mechatronics (ICOM). Kuala Lumpur. 2011.
- [6] Arbab NK, Dai Y, Syed AA, Xu XY. 3DoF Model Helicopter with Hybrid Control. *TELKOMNIKA Indonesian Journal of Electrical Engineering*. 2014; 12(5): 3863-3872.
- [7] Rahimi MR, Hajighasemi S, Sanaei D. Designing and Simulation for Vertical Moving Control of UAV System using PID, LQR and Fuzzy Logic. *International Journal of Electrical and Computer Engineering (IJECE)*. 2013; 3(5): 651-659.
- [8] Constantine H, Steven R, Mario S. *Quantitative Feedback Theory: Fundamentals And Applications*. CRC Press. 2006.
- [9] Rodrigues J, Chait Y, Hollot C. *A New Algorithm for Computing QFT Bounds*. Proceedings of 1995 American Control Conference - ACC'95 (6). 1995: 3970-3974.
- [10] Xing X, Yuan D. *Quantitative Feedback Theory and Its Application in UAV's Flight Control*. Automatic Flight Control Systems - Latest Developments. Dr. Thomas Lombaerts (Ed.). Shanghai: Intech. 2012.
- [11] Vaheed B, Ali K. *Optimal Design of Robust Quantitative Feedback Controllers Using Linear Programming and Genetic Algorithms*. Proceedings of International Control Conference. Glasgow. 2006: 291-296.
- [12] Quanser. *Quanser 3-DOF Helicopter Reference Manual*. London: Quanser Incorporated. 2010.